



# OST 100/150

COMPREHENSIVE REFRACTION UNIT  
FOR SMALL SPACE



# OST 100/150 COMPACT SERIES

OST 150\* additional features:

Chart projector holder with variable lighting



Lift-up elbow rest



Foot rest

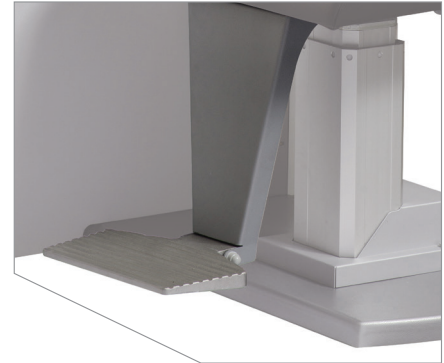

## OST 100 « STANDARD PACK » CONFIGURATION:

2 instruments sliding table  
Motorized chair  
Projector plate  
Self-balancing refractor arm.  
Led lighting

## OST 150 CONFIGURATION:

Standard pack + Lift-up elbow rests  
and footrest

## OPTIONS:

Additional projector plate  
110V power supply  
Stand for keyboard  
Fixed chinrest

Side unit body covers:

- Red (RAL 3001)
- Blue (RAL 5005)
- White (RAL 9016)

## SPECIFICATIONS

**Chair maximum load:**  
150 kg

**Sliding tabletop:**  
Dimensions: 42 x 82 cm  
Max. weight: 50 kg

**Versions:**  
Right or left handed version

**Power supply:**  
230V-50/60Hz

**Dimensions:**  
1.25 (L) x 1.5 (P) x 1.80 (H)m

**Weight:**  
195 kg

OST 100. Side view

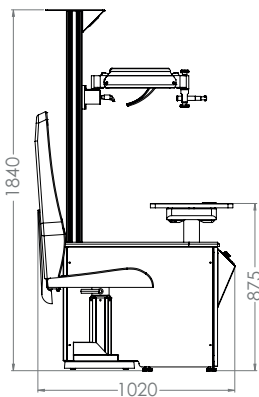

OST 100. Top view

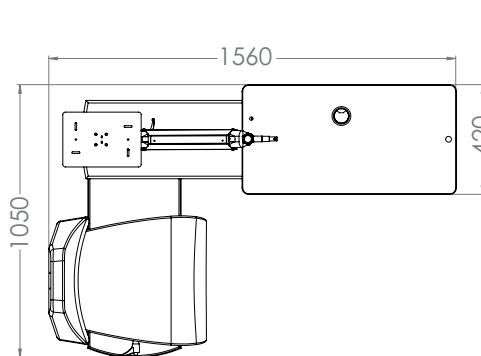

As improvements are made, images and specifications are not contractually binding and may be changed without prior notice.



**ESSILOR INSTRUMENTS**

81 boulevard Jean-Baptiste Oudry  
94000 Créteil  
France  
Tél. 33(0)1 49 80 62 80  
www.essilor-instruments.com

